

It´s always worth taking a look ...

... to find good ideas and products

engelGmbH

Something about us:

Since 1964 we are engaged in the industry.

A multitude of special tasks had been accomplished.

We participated and are still participating in many development plannings.

- We assist you in finding ways of solution for new installations/plants and also for the improvement of existing product lines in the field of flexible material guide, rolling-up, processing, handling and packaging.
- Together with you, we elaborate the catalogue of requirements, project drafts and we compose the corresponding technical data in order to facilitate the project handling and operation.
- You may rest assured, that this **cooperation will be effected on confidential basis.**

- For many years we are in close cooperation with our contractual partners: - engineering works and accessory producers of high reputation. For your specified order we are able to appoint qualified specialists.

- So, you can be sure being offered an optimal solution.

Our clients show confidence in us:

- mechanical engineering (for extruder installations, winding- and cutting machines)
- foil process engineering (plastic sheeting- and aluminium foils)
- blown film manufacturers
- flat foil manufacturers
- paper- and textile manufacturers

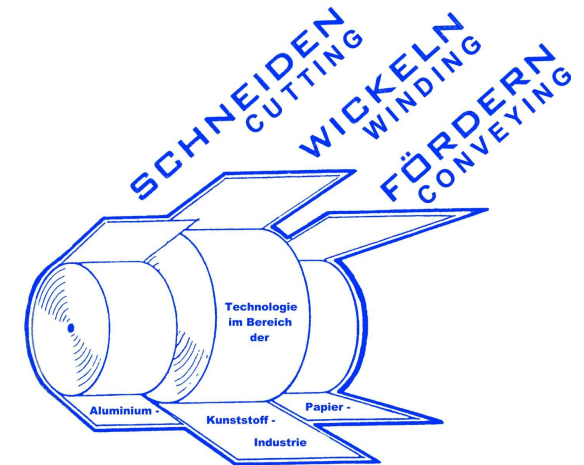

engel GmbH

Gaußstraße 5

31787 Hameln

Geschäftsführer : Ludwig Engel

Telefon: +49 (0) 51 51 / 674 53

Telefax: +49 (0) 51 51 / 674 63

Web: <http://www.engel-hameln.de>

e-mail: info@engel-hameln.de

Double razor blades- tube-slitting-holders

(type 73697/E01) for double-sided
splitting of a blown film tube

- the complete unit exists of aluminium alloy with wear-resistant surface application
- **long lifetime**
- ball-bearing guide rollers
- air connection 1/8"
- side air nozzles effect a sound film flow
- trade-customary industrial razor
- magnetic razor holder with protection against accidentally touch
- **a change of razors is possible during the production without interruption of the cutting process**
- **assembly holes suitable for many machines**



Double razor blades – with heated blade holder for films (typ 73697/E02/HB) with attached trimmer unit



Double razor blades for thin and sensitive films (type 73604/E02)

- Without leadership roles
- Slim design



Special designs to customer:



engel GmbH

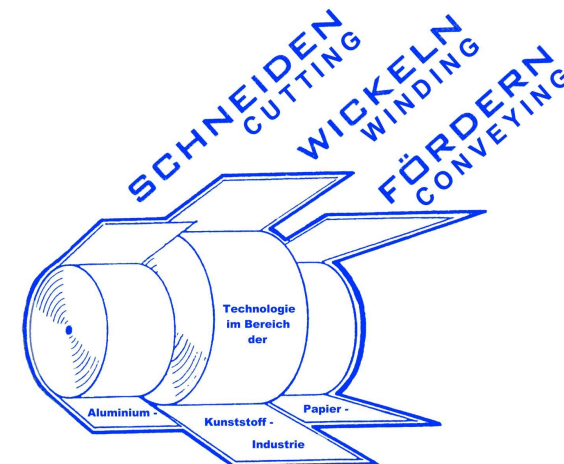

engel GmbH

Gaußstraße 5

31787 Hameln

Geschäftsführer : Ludwig Engel

Telefon: +49 (0) 51 51 / 674 53

Telefax: +49 (0) 51 51 / 674 63

Web: <http://www.engel-hameln.de>

e-mail: info@engel-hameln.de

Pneumatic razor holder

(Typ 73602/E41-1) for longitudinal cut

- 1 pneumatic razor rod in material direction
- pneumatic razor rods for different industrial razor, for example with TIN- or CrN coating, as special version also for ceramic razor
- suitable for simple- or double longitudinal cut 10 mm (other widths possible on request)
- razor rod with magnetic razor holder
- **Change of razor without tool**
- in unpressurized state, the razors are in neutral position completely hidden (**maximum safety**)
- continuously variable cutting width possible



Pneumatic double razor holder

(Typ 73602/E41-2) for longitudinal cut

Supplement:

- 2 pneumatic razor rods in material direction one after another
- **A change of the razor is possible during**

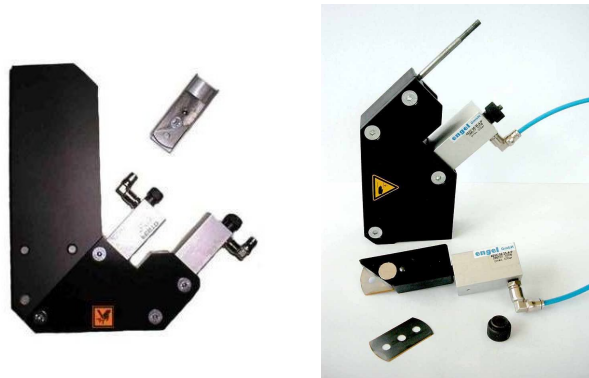

Special designs to custome:



engelGmbH

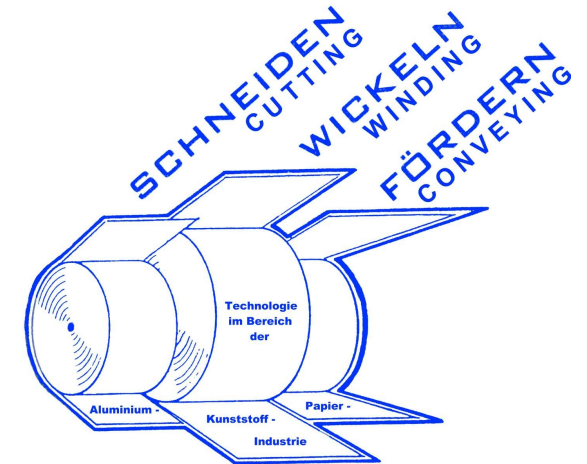

engel GmbH

Gaußstraße 5

31787 Hameln

Geschäftsführer : Ludwig Engel

Telefon: +49 (0) 51 51 / 674 53

Telefax: +49 (0) 51 51 / 674 63

Web: <http://www.engel-hameln.de>

e-mail: info@engel-hameln.de

Industrial razor holder

(type 73604/E51-1) for longitudinal cut

- 1 industrial razor in material direction course
- razor holder for industrial razor, for example with TIN- or CrN- coating, as special version also for ceramic razor
- suitable for simple cut
- razor rod with magnetic razor holder
- simply adjustable
- change of razor with flat-nosed pliers
- completely hidden razor in neutral position (**maximum safety**)
- in case of several holders side-by-side, a continuously variable cutting width possible from 10 mm on



Industrial razor holder piece

(Typ 73604/E52-2)

- industrial razor holder one-piece
- **change of razors and cutting adjusting without tool**



engel GmbH

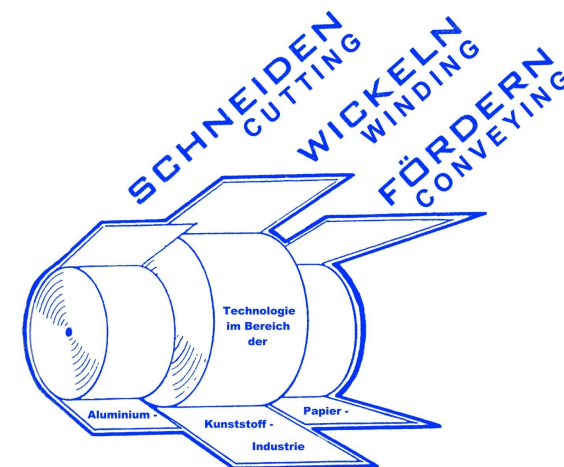

engel GmbH

Gaußstraße 5

31787 Hameln

Geschäftsführer : Ludwig Engel

Telefon: +49 (0) 51 51 / 674 53

Telefax: +49 (0) 51 51 / 674 63

Web: <http://www.engel-hameln.de>

e-mail: info@engel-hameln.de

Heated razor holder

for longitudinal cut in the field of plastic process engineering - type 73603/E11

- suitable for simple- or double longitudinal cut 10 mm (other widths possible on request)
- heated razor holder for different industrial razor, for example with TIN- oder CrN-coating
- increase of edge life of the razor
- clean cutting edges (visible under microscope)
- temperature control of the heating cartridge by single channel regulator



Typ 73605/E14

- special razor holder for existing machine holders



Typ 73605/E31

- Electrical connection for heating cartridge



Typ 73603/E11

- double longitudinal splitting cut 10 mm (other widths possible)

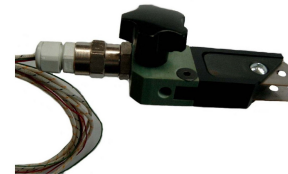

Typ 73606/E64

- single channel temperature regulator



engel GmbH

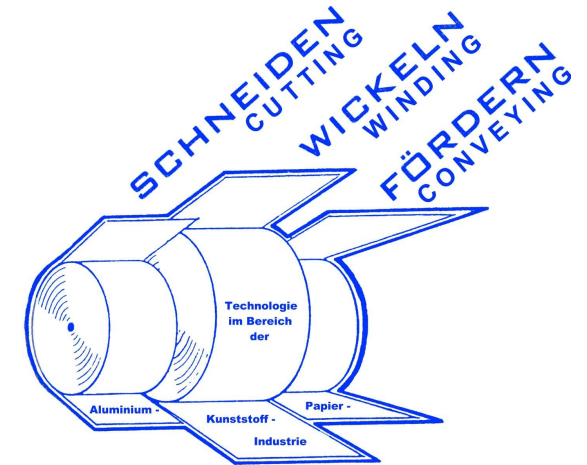

engel GmbH

Gaußstraße 5

31787 Hameln

Geschäftsführer : Ludwig Engel

Telefon: +49 (0) 51 51 / 674 53

Telefax: +49 (0) 51 51 / 674 63

Web: <http://www.engel-hameln.de>

e-mail: info@engel-hameln.de